



# PNEUMATIC VACUUM ELEVATORS LLC

12602 N.W. 115<sup>th</sup> Ave, Medley, FL 33178

Phone: 305-884-1091

## Maintenance Manual

The following is a check list for a routine maintenance check on PVE elevator. One qualified technician should be able to perform the task but two would be ideal. The general maintenance check should take about 30 – 45minutes. Note: this check list does not replace the “Maintenance and Malfunction” section of the PVE manual. If there are any trouble shooting tasks that have to be performed the “Maintenance and Malfunction” section should be referred to. Further this general check assumes the technician has been fully training in the Pneumatic Vacuum Elevator product.

ONLY elevator technicians that have been fully trained by Pneumatic Vacuum Elevators can service vacuum elevators.

It is recommended that every 6 months a maintenance check should be performed.

Client Name \_\_\_\_\_

Date \_\_\_\_\_

Technician at site \_\_\_\_\_

PVE Model Number \_\_\_\_\_

Serial Number \_\_\_\_\_

Order Number \_\_\_\_\_

Name & Address of maintenance

\_\_\_\_\_  
\_\_\_\_\_  
\_\_\_\_\_

---

# CONTENTS

<u>Page</u>	<u>Title</u>
3	Important Safeguards (warnings)
4	Requirements of elevator owner
5	Requirements of maintenance organization
6	Installation risk assessment
7	General Check List Table
8	Trip List
9	Passenger Rescue Operation
10	Door Adjustment
11	Cont. Door Adjustment
12	Figure 2
13	Figure 3
14	Replacing weather strip
15-26	Table Problem / Solution (T1-T11)

# IMPORTANT SAFEGUARDS

When using an elevator, basic precautions should always be followed, including the following:  
READ ALL INSTRUCTIONS BEFORE USING THIS VACUUM ELEVATOR.

## WARNING

- Never allow children or people unfamiliar with the instructions to operate the elevator.
- The elevator is intended for the transportation of people from one landing to another.
- Keep all nuts, bolts and screws tight to ensure that the equipment is in safe operating condition.
- Never open the door when in operation.
- Never remove car ceiling.
- Never remove any of the covers that the elevator has.
- Do not use elevator when covers have been removed.
- ONLY an authorized PVE dealer distributor is to install, work on, and/or service the elevator.
- Do not force or kick the doors open.
- Do not lay any objects against the cylinder elevator walls.
- Never wedge anything between the car and the cylinder.
- Do not remove any weather stripping located on the doors.
- Do not remove any hardware that is part of the elevator or shipped with the unit.
- Do not use elevator if ambient temperature is less than 65°F (18°C).
- Do not spill water on any of the electronics.
- Do not obstruct the door opening, door clearance, and door locks.
- Keep your door key in a secure place.
- Do not use elevator if home is under construction and there is dust / particles that are air born.
- If voltage exceeds nominal 220VAC it can cause damage to system. Assure a regulated, clean, and dedicated line is supplied to elevator.
- Turn OFF motor circuit breaks (power interrupts) before entering hoistway (cylinder)
- An approved ANSI or EN 131 “A-Frame” ladder is required to access controls.
- Elevator may have a small step into car.

# Requirements of Elevator Owner

The following are important items the owner of elevator needs to comply with.

- The owner of elevator needs to maintain the elevator and installation in a safe operating condition. To fulfill this the owner shall use a maintenance organization complying with the requirements of the elevator Standard.  
*Note: It is high recommended that owner uses a company that has an adequate and proper insurance coverage as required of any contractor.*
- The owner of elevator needs to take care of any National regulations and other requirements, where relevant, and their implications on maintenance.
- The owner of elevator needs to have the maintenance organization carry out a service (maintenance) if the installation will or has remained unused for a long period of time before first being put into service.
- It is recommended that the owner of elevator to have the same maintenance organization in case of multiple installation having the same elevator and installation.
- The owner of elevator needs to have a phone connected and working in the car with 24hrs line service.
- The owner of elevator needs to inform the maintenance organization immediately:
  - about any perceived abnormal operation of abnormal changes in its direct environment.
  - after putting the installation out of service in the case of a dangerous situation
  - after any rescue intervention by their authorized and instructed person(s)
  - before any modification related to the installation and/or its environment
  - before any authorized third party inspection or works other than maintenance works are carried out on the elevator
  - before taking the elevator out of service for a prolonged period of time
  - before putting the elevator back into service after a prolonged period of non operating time
- The owner of elevator needs to ensure the name and telephone number of the maintenance organization is ready available to anyone, permanently affixed and clearly visible.
- The owner of elevator needs to ensure that the key(s) of the elevator (doors, machine, and car if applicable) are permanently available in the residence and are used only by persons authorized to gain access.
- The owner of elevator needs to keep the access to working areas and working rooms safe and free for the maintenance persons and to inform maintenance organization about any hazard or change in the workplace and/or the access ways.
- The owner of elevator needs to take into consideration the consequence of the risk assessment.
- The owner of elevator needs to ensure the risk assessment is carried out.
- In addition to those examinations and test which the owner of elevator entrusts to the maintenance organization, the owner needs to carry out periodically, in their own interest, the following checks:
  - Landing doors
  - Call buttons/controls at landing and car
  - Operation / service of phone
  - Safety signs
  - or change in the workplace and/or the access ways.
- If a “fire stop rating” is required, in order to meet International Building Code and/or International Residential Code, of the hoistway then the owner of elevator will have to take additional steps to meet the code.
- If elevator is exposed to HIGH sunlight then the owner of elevator will have to take additional steps to reduce the amount of heat conditioned in car.
- If elevator is installed in a flood zone then the owner of elevator will have to take additional steps.

# Requirements of Maintenance Organization

The following are important items the maintenance organization needs to comply with.

- The maintenance organization needs to carry out the work of maintenance in conformity with the instructions and check list. After the checks are performed the maintenance organization needs to determine if conformity or additional steps that need to be taken.
- The maintenance organization needs to verify that the elevator is being used for its intended environmental conditions.
- The maintenance organization needs to ensure that a risk assessment for any working area and for any maintenance operation has been carried out taking into account the installer's maintenance instructions and all information supplied by the owner of elevator.
- The maintenance organization needs to inform the owner of elevator of any work that needs to be carried out as a consequence of the risk assessment especially for the access and/or the environment related to the installation.
- The maintenance organization needs to carry out a maintenance plan so that preventive maintenance is suitable for the installation and maintenance time is as short as reasonably practicable, without reducing the safety of persons, in order to minimize the non-operational time of elevator.
- The maintenance organization needs to adapt a plan for maintenance so as to take into account of any predictable failures due to misuse or mishandling of equipment.
- The maintenance organization needs to carry out maintenance operations by competent maintenance persons and provided them with the necessary tools / equipment.
- The maintenance organization needs to maintain the competency of the maintenance persons.
- The maintenance organization needs to provide a 24hr, all year round call-out service for rescue of persons.
- The maintenance organization needs to keep records of the result of each intervention due to a failure of the elevator. These records shall include the type of failures in order to detect any repetition. They shall be available to the owner of elevator upon request.
- The maintenance organization needs to put out of service the elevator if the maintenance organization is aware of a dangerous situation, detected during the maintenance, which cannot be eliminated immediately, and to inform the owner of the elevator of the need to keep it out of service until repaired.
- The maintenance organization needs to be organized to provide the necessary spare parts for any repair.
- The maintenance organization needs to make available for the attendance of a competent maintenance person(s), given at a reasonable notice, for any inspection carried out by an authorized third party or for building maintenance works to be carried out in the areas reserved for the maintenance organization.
- The maintenance organization needs to inform in due time the owner of elevator about necessary progressive upgrading of the elevator.
- The maintenance organization needs to organize rescue operations, even with subcontractor(s), and to make provision for circumstances such as fire, panic, etc.

# Installation Risk Assessment

It is necessary that a risk assessment be carried out to determine the safety in maintenance operations of the elevator by adopting safety measures. Safety measure instructions on the elevator and in the building/residence shall be provided by the installer and by the owner of the elevator respectively. For safe maintenance and to provide relevant instructions, it is necessary, first of all, to identify the maintenance operations.

Maintenance operations are:

- a) those operations considered necessary for a correct and safe functioning of the elevator and its components after the completion of the installation
- b) those operations considered necessary during the “life” of some components, determining as far as possible, the time or condition after which the functioning or integrity of the component is no longer ensured even if correctly maintained.

It is necessary to inform and warn the maintenance persons about residual risks that can arise from the necessary removal of certain guards to carry out specific maintenance operations.

The maintenance instructions and warnings shall prescribe the procedures and operating modes intended to overcome these risks and, if it is necessary, to specify personal protective equipment, instruments, tools and provision to be used. Below is a chart that can be used to take into account risks but should not be limited to it.

Elements	Car	Machinery	Area outside lift
Unsuitable access (ladders not secure, no hand-rails, etc.)			
Inadequate lighting (including access areas)			
Slippery floor surface			
Unsuitable dimensions (maintenance places)			
Identification of the car position			
Indirect contact with electricity			
Switches			
Crushing by moving parts (car)			
Manual handling			
More than one maintenance person working			
Absence of a means of communications			
Ventilation and temperature			
Dangerous substances			
Falling objects			
Entrapment			
Means/control for rescue operation			
Fire			
Unexpected water/dirt			

If the risk assessment indicates that additional specific warnings are required for the purpose of maintenance, these shall be affixed directly on the elevator/component or, when this is not possible, in the close vicinity. Markings, signs, pictograms and written warnings shall be readily understandable and unambiguous. Readily understandable signs and pictograms shall be used in preference to written warnings. Information affixed directly on the elevator/installation shall be permanent and legible.

The certified elevator technician needs to perform the general check as outlined.

## General Check

- |   |   |
|---|---|
| <p>1) Connect Power<br/>__ a) check PVE board status is “waiting”<br/>__ b) check elevator car has power<br/>__ c) check control box lid switch</p> <p>2) Call Elevator to 1<sup>st</sup> Floor<br/>__ a) car light &amp; fan work<br/>__ b) alarm works<br/>__ c) car pushbutton works<br/>__ d) Ground floor door lock engages<br/>__ e) motors turn on<br/>__ f) car elevates to 1<sup>st</sup> floor<br/>__ g) car stops and engages on 1<sup>st</sup> floor<br/>__ h) 1<sup>st</sup> floor door releases<br/>__ i) 1<sup>st</sup> floor call pushbutton works</p> <p>3) Call Elevator to Ground floor<br/>__ a) car pushbutton works<br/>__ b) motors turn on<br/>__ c) 1<sup>st</sup> floor door lock engages<br/>__ d) motors turn off<br/>__ e) electromagnetic vacuum valve opens<br/>__ f) car lowers to Ground floor<br/>__ g) Ground floor door releases<br/>__ h) Ground floor call pushbutton work</p> <p>4) Call Elevator to 2<sup>nd</sup> Floor<br/>__ a) car pushbutton works<br/>__ b) motors turn on<br/>__ c) 1<sup>st</sup> floor door lock engages<br/>__ d) car elevates to 2<sup>nd</sup> floor<br/>__ e) car stops and engages on 2<sup>nd</sup> floor<br/>__ f) 2<sup>nd</sup> floor door releases<br/>__ g) 1<sup>st</sup> floor call pushbutton work<br/>__ h) car lowers to 1<sup>st</sup> floor<br/>__ i) Ground floor call pushbutton work<br/>__ j) car lowers to Ground floor</p> | <p>5) Door Locks<br/>__ a) open and close door (use door key). Note: you must allow the door closer to be the only force to close the door. Do not push!<br/>__ b) once door is closed the door lock<br/>__ c) assure that the door lock functioned as required, if not align.<br/>__ d) repeat steps a thru c five times</p> <p>6) Elevator – Visual check<br/>__ a) check top of car to ensure no derby has entered.<br/>__ b) check door weather stripping (replace if needed)<br/>__ c) check the car flap<br/>__ d) check the car seal<br/>__ e) check visually the overall cleanliness of unit<br/>__ f) check door closer to ensure proper operation<br/>__ g) check that there is nothing obstructing the door opening and/or the door frame which could prevent the door from closing properly</p> |
|---|---|

II. The certified elevator technician needs to check the trip count on unit. Based on the count an associated service may need to be performed.

## Trip List

Schedule Check	Component	Action	Date
Every 15,000 thru 20,000 Trips or 4 to 5 years	Seal	Check the car seal for signs of wear. If wear is visible then change seal.	
Every 25,000 thru 30,000 Trips or 5 to 6 years	Motors	Check the motors to ensure all are functioning. If need be change motor(s).	
Every 40,000 thru 45,000 Trips or 8 to 9 years	Door Closer	Check the door closer at each landing for proper closing. If door closer shows sign of wear please change.	
Every 55,000 thru 60,000 Trips or 10 to 11years	Travel Cable	Check travel cable. Ensure that it does not have kinks or wear on jacket.	

Note: above table is based on a typical residence usage

## Brake - Full Load Free Fall

Model	After Free Fall	Component	Action
30	1	Brakes	Replace car brakes after indicate full load free fall.
37	5	Brakes	Replace car brakes after indicate full load free fall.
52	5	Brakes	Replace car brakes after indicate full load free fall.



# Passenger Rescue Operation

*What to do if for some reason the elevator door will not open and a passenger finds his/herself in the car interior. How can someone which is outside the elevator assist the passenger to exit? The following cases are presented according to the location of the stranded car.*

*E1. The car is stuck on ground floor and you are outside the car.*

1. Insert the door opening key in the door hole, make a ¼ turn clockwise and open the door.

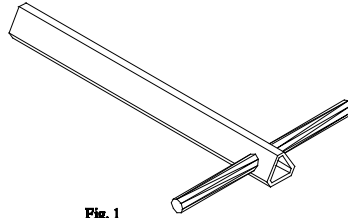

Fig. 1

Figure 1

2. Do not operated elevator until it has been fully repaired.

**WARNING: Once door is open and person is out, close the door. You should block entrance until the elevator is fully functional again.**

*E2 – The car is found between floors or on the upper floor with a passenger.*

The passenger can be assisted to exit the elevator in the following ways:

1. If the car is at a door entry/exit then perform the above mentioned step as described in E1
2. If there was a vacuum loss determine what caused the problem, fix it and restart the vacuum manually by using the manual override on the motor contactor found in the control box. Activate the motor contactor for two to three seconds. This will allow the car to disengage from its safeties and lower itself to the ground floor.

**WARNING: Elevator should not be operated again until it is fully functional again. Blocking the entrance is required.**

3. Another option is to remove the rubber seals located around the perimeter of each polycarbonate sheet. Once the seals are removed the polycarbonate sheet can be removed and the person rescued.

**WARNING: The entry section used to rescue the passenger needs to be blocked off immediately as to avoid any injury by person(s) walking by elevator. Elevator should not be operated again until all parts have been placed back and has the elevator fully functional again.**

The following are important items the owner of elevator needs to comply with for rescue operation.

- \*Need to have a person(s) authorized to be trained by maintenance organization to rescue trapped passenger.
- \*Need to ensure training is appropriate to the specific installation and updated.
- \*Need to call the maintenance organization is called when the authorized person(s) are not able to \*move the car through use of the manual/electric emergency device.
- \*Need to inform their authorized person(s) about any conditions for which only the maintenance organization shall carry out a rescue operation.

# Door Adjustment

On the vacuum elevator one must keep in mind 3 important points in adjustment of the door.

- Mating of the door pin with door lock
- Activation of door close sensor
- Seal around door frame. (Principally on the upper floor doors)

## Mating of the door pin with door lock

The adjustment / setting of the door pin with the door lock is very important as this is required for the car to fully operate else the system will detect a door unlock error and shut down. (See table Problem / Solution in this manual for more tips on trouble shooting.) Before discussing the adjustment it is essential that the function is completely understood. As shown in figure 2, the door lock is located in the cylinder column and the door pin on the door frame. In figure 2 & 3, it is illustrated that the mating of the door pin in the center of the door lock barrel allows for the complete extraction of the door lock barrel from the door lock. When this full movement occurs then the systems recognizes the door to be fully locked.

### *Adjustment*

The door frame has a slot which can allow the door pin to be moved in any direction permitting for an alignment to be accomplished with the center of the door lock barrel. By inserting the door key into the door pin and using a metric wrench the nut on the door pin can be loosened and the door pin moved for alignment. Once the ideal position is found tighten the nut again. Note: do not push on the door frame as this additional force will never be present in normal use.

## Activation of door close sensor

The alignment of the door close sensor is very important as this is required for the car to operate else the system will detect a door is open and will never move. As shown in figure 2, the door close sensor is located in the cylinder column. In figure 2 & 3, it is illustrated that the door close sensor has a pivoting switch in which is activated by the door frame.

### *Adjustment*

The door close sensor alignment to the door is done by adjusting the door frame hinges, see “Seal around door frame”.

### Seal around door frame

Maintaining a seal around the door frame is important on the four edges. Note: Some very minor leaks are acceptable.

#### *Adjustment*

The door frame can be adjusted / aligned with the cylinder frame by the door hinges. As shown below in figure 4, the door frame and hinge are joint together by an eccentric screw (shown in green). By rotating the eccentric screw this will move the position of the door frame. The hinge (shown in red) as well can be moved by loosening the socket allen screw which joints the hinge to the cylinder column and moving its position.

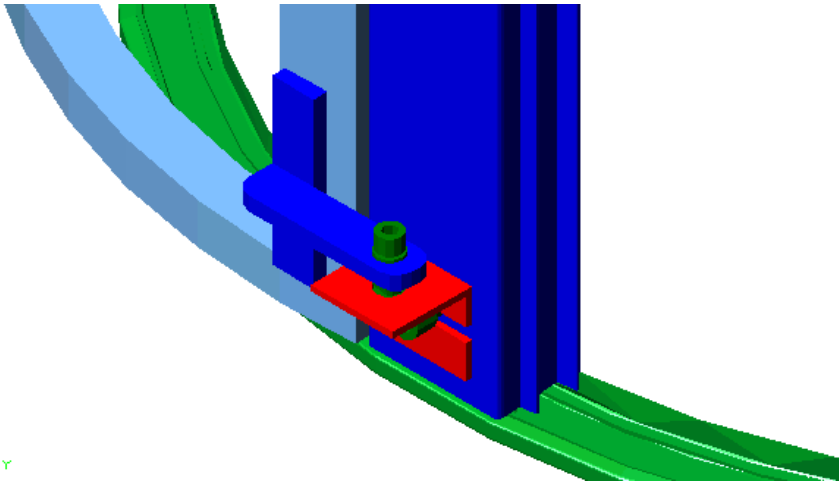

FIGURE 4

**FIGURE 2**

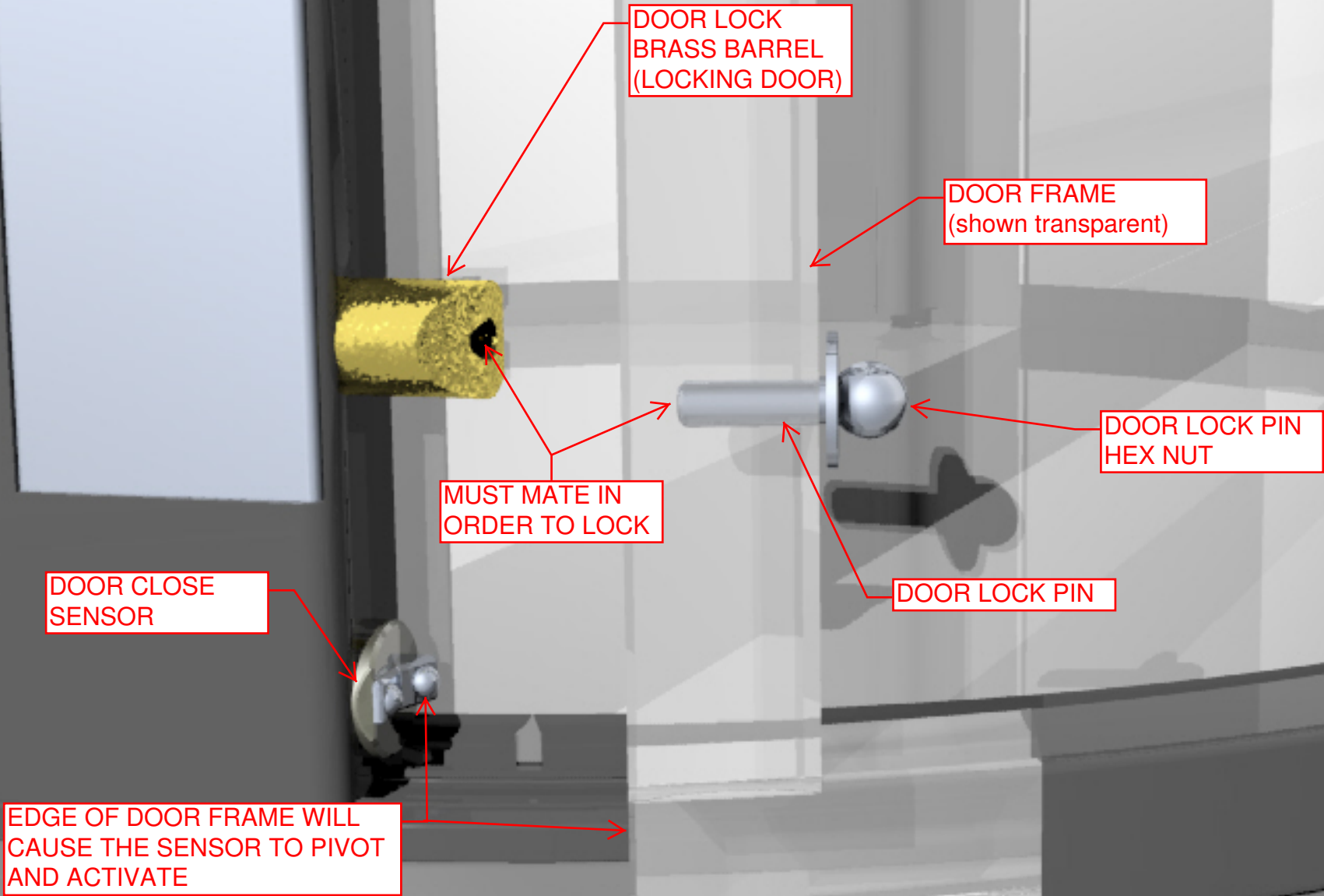
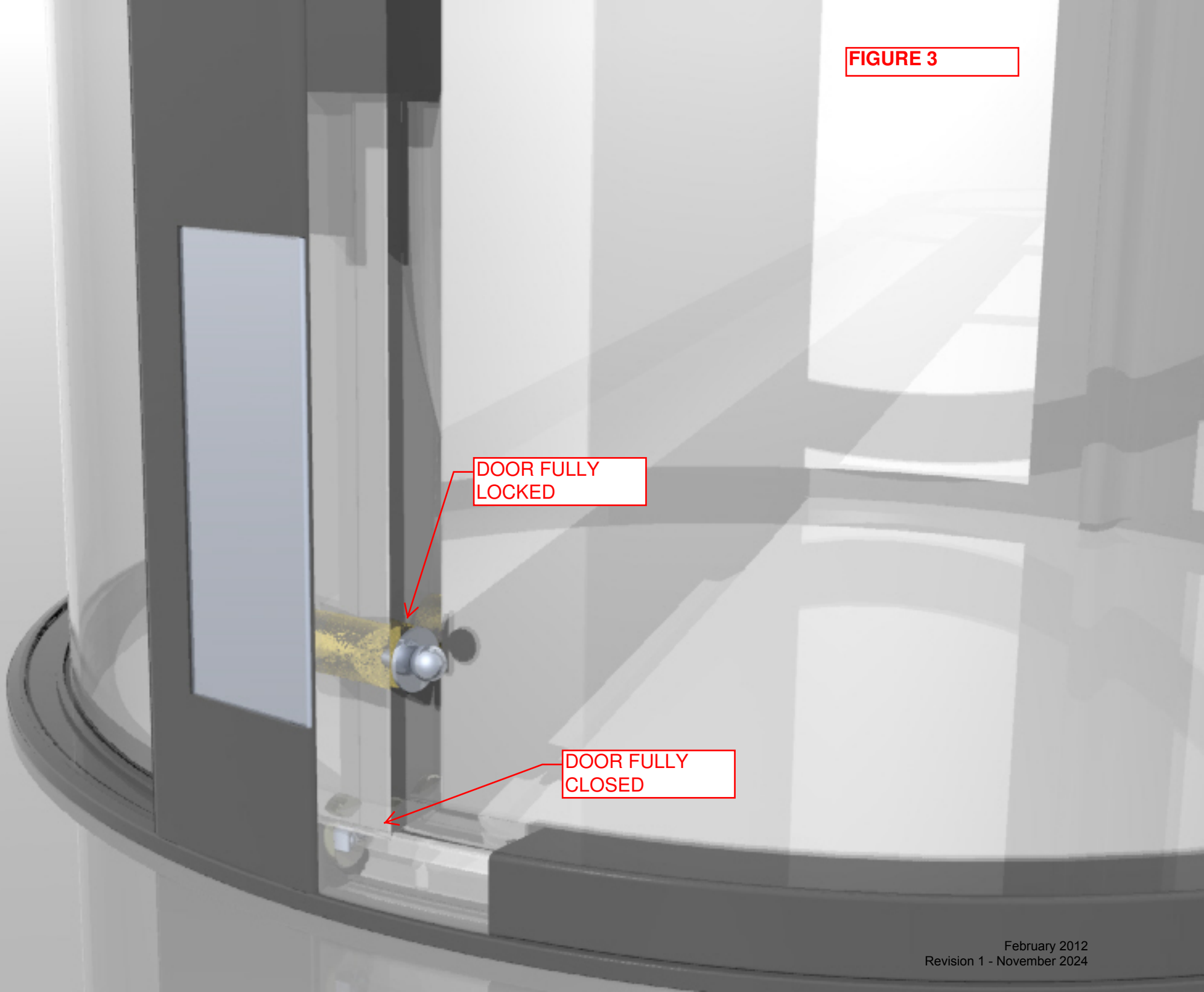

FIGURE 3



DOOR FULLY  
LOCKED

DOOR FULLY  
CLOSED



## Replacing

### Weather Strip

On the vacuum elevator in the entry/exit area the door frame seals against the cylinder. As a seal a weather strip is used. If this strip becomes worn just replace it with the same or equivalent – [MD Building, model number : 63560].

### *Process Replacing*

Turn primary power off to elevator. Open the door at the landing in which the seal is to be replaced.

**WARNING: Once door is open the block entrance in a way that work can still be performed until the elevator is fully functional again.**

At one of the four corners grab the end of the weather strip and peel. Next clean area with degreaser. Install the new weather strip seal.

### POLYCARBONATE SHEETS

For the State of New Jersey the polycarbonate panels are to be replaced every 10 years by an authorized PVE distributor.

<b>Problem</b>	<b>Possible cause(s) for this</b>	<b>Solution</b>	<b>N°</b>
The elevator does not start (does not respond to any given command).	There is no electricity coming from the load center (primary power box).	Open the control box and verify that PVE board has power. Also, verify that the electricity in the residence is up and running and that the main disconnect feeding the elevator is in the ON position.	1
	The master circuit breaker or any of the other circuit breakers are in the off position.	Open the control box cover and place the circuit breaker(s) in the <b>ON</b> position.	2
	The control box cover is open or is not properly shut	Close control box cover and tighten screws.	3
	One of the elevator doors was left open or not closed properly.	Check all doors and door close sensors. Remove any obstructions which may interfere with the correct closing.	4
	Failure in the electrical circuit.	Check / troubleshoot all electrical circuits, cabling, call buttons and turbines assuring all are functioning.	5
The car goes up a few centimeters and goes back down.	The door lock does not engage properly.	Verify that the door is leveled ( <b>see rules of operate,#1</b> ). Verify that there is no obstruction which may cause the sensor not to work properly. Align the door pin.	6

The car is ascending at a slower pace than normal. There is a loss of air through the upper door



Take apart the cylinders, clean the structural ring

The car is ascending at a slower pace than normal.  
(cont.)

There is a loss of air between the jointing cylinders.



The car ascends to the upper floor and then gets stuck up against the Head.	The upper magnetic sensor (MU) does not work.	Check sensor and its electrical circuit.	14
	One or more turbine contactors are mechanically stuck keeping the electrical circuit shut.	Check the turbine motor contactors / relay. Replace if necessary	15
The car ascends to the upper floor and hits the Head unit.	The upper magnetic sensor (MU) is too high up.	Lower the upper magnetic sensor (MU).	16

There is a vacuum leak due to previously described problems.

Please refer to #

The car roughly lands on the ground floor.



The car stops roughly at the upper floor.

There is a vacuum leak due to previously described problems

Please refer to #

The emergency brakes do not actuate in the absence of vacuum	Bad installation of the brake blocks or the car roof springs.	Please refer to procedure # 4.	29
	An obstruction is present between the brake blocks or levers causing them not to actuate.	Clean the surface of the cylinder. <b>(See Installation Manual – Step 12).</b>	30
	The brake blocks have worn out or have some obstruction.	Check brake blocks and replace if necessary	31 32
Rubbing noise between the car and the cylinder.	Misalignment of the car guides (rails).	See Rules of Operation #2.	33
	The car guides are worn out.	Remove and replace guides	34
The car fan and light do not turn on.	The light or the fan has burned out.	Replace if necessary.	35
	Blown electrical circuit.	Check the circuit breaker and wiring.	36
	Elevator is in emergency mode.	If car light/fan turn off during a descend command, this indicates that one of the doors is misaligned. Check all doors and align.	37

© Proprietary

“ Information contain herein is the property of Pneumatic Vacuum Elevators LLC. No reproduction or disclosure of this information may be made by the recipient to any person or organization without the written consent of Pneumatic Vacuum Elevators LLC.”

## REGULATION PROCEDURES

### 1. Door alignment

1.1. The height of the doors is regulated by: adding or removing the flat washers to the hinge, adjusting the hinge position, or by adjusting the eccentric screw on the hinge.

### 2. Car guide alignment

2.1. In order to properly align the car guide you must have the car on the ground floor and turn **OFF the elevator**.

2.2. From inside the car remove the ceiling by unscrewing the four allen screws. Disconnect the car fan/light.

2.3. Loosen the guide bolts and move them along the column in the corresponding direction. Two of the upper guides are screwed conjunctly to the car locking system (CLO). Thus, when you loosen the guide screws it is necessary to regulate the car locking system (CLO) as well.

2.4. If the guide is worn out, the entire guide must be replaced. To do this, you must completely remove the bolts and remove the guide in an upward fashion. Introduce the new guide and bolt, remember to regulate guide.

2.5. For the regulation of the lower guides it is necessary to anchor the car at a midway height of the ground level door, this is accomplished by activating the emergency braking system. Turn off elevator. Please refer to step #8 of the Operating Manual.

2.5.1. Once the car is anchored, from the bottom of the car loosen the guide screws and move the guides along the column in a corresponding direction. If the guide is worn, completely change the guide by removing it in a downward manner.

2.5.2. To restart the operation of the elevator follow step #8 on the Operating Manual.

### **3. Car Lock (CLO) adjustment**

- 3.1.** The car locks (CLO) are the car locks which allow the elevator to land/stop at the upper levels. The car locking pins (CLO) are set in place on top of the car guides. This is why the regulation of the locks must be done in conjunction with the regulation of the guides.
- 3.2.** The locking pin must be centered as it relates to the

## 4. Emergency Brake Replacement

For Model 30" & 37" see steps 4.1 and 4.2 for Model 52" see steps 4.3 and 4.4

4.1. In order for the emergency brake system to function properly the top of the brake blocks should be positioned in a way that there is light between the brake blocks and column (3 mm as it is shown in the figure below.)

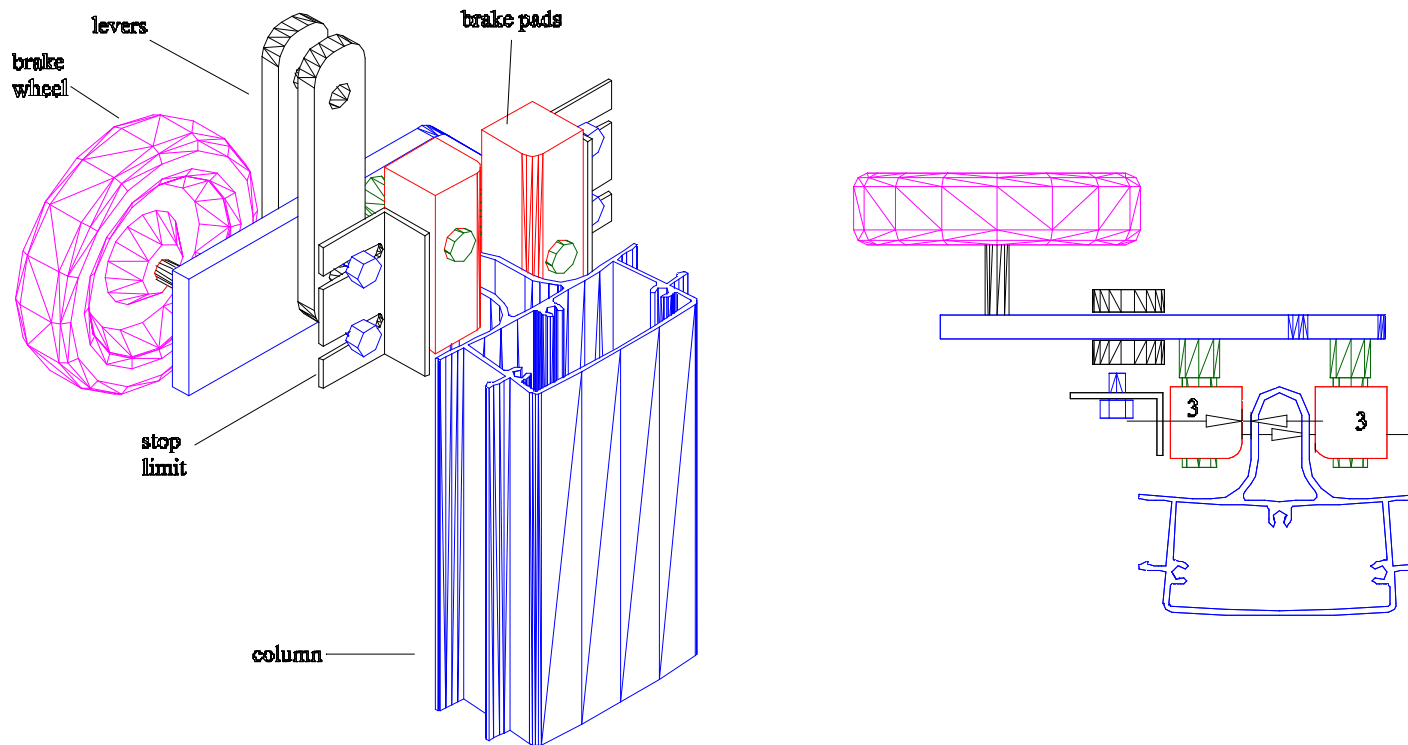

© Proprietary

"Information contained herein is the property of Pneumatic Vacuum Elevators LLC. No reproduction or disclosure of this information may be made by the recipient to any person or organization without the written consent of Pneumatic Vacuum Elevators LLC."



**4.2.** The brake system works in conjunction with the car roof. The car roof springs should have the same tension on all eight screws which help seal the car (screws are 5/16



**4.4.** The brake system works in conjunction with the car roof. The car roof springs should have the same tension on all eight screws which help seal the car (screws are 5/16



- 7.6. Before inserting the new seal assure that the seal edge is free from any particles and has liquid silicone as a lubricant.
- 7.7. Insert the new seal carefully. Note: the orientation of the travel cable.
- 7.8. Place the 8 screws and their assemblies.
- 7.9. Reassemble the Head Unit and connect travel cable. Turn power to unit and allow the car to descend to the ground floor before giving the travel cable its final tension. *Caution: make sure that car does not rest on top of travel cable.*

## **8. Inspection of Dampers.**

- 8.1. In order to do this, the car must be at the landing above the ground floor.
- 8.2. **Turn the power off to elevator.**
- 8.3. Using the door key open the ground floor door. Insert the