

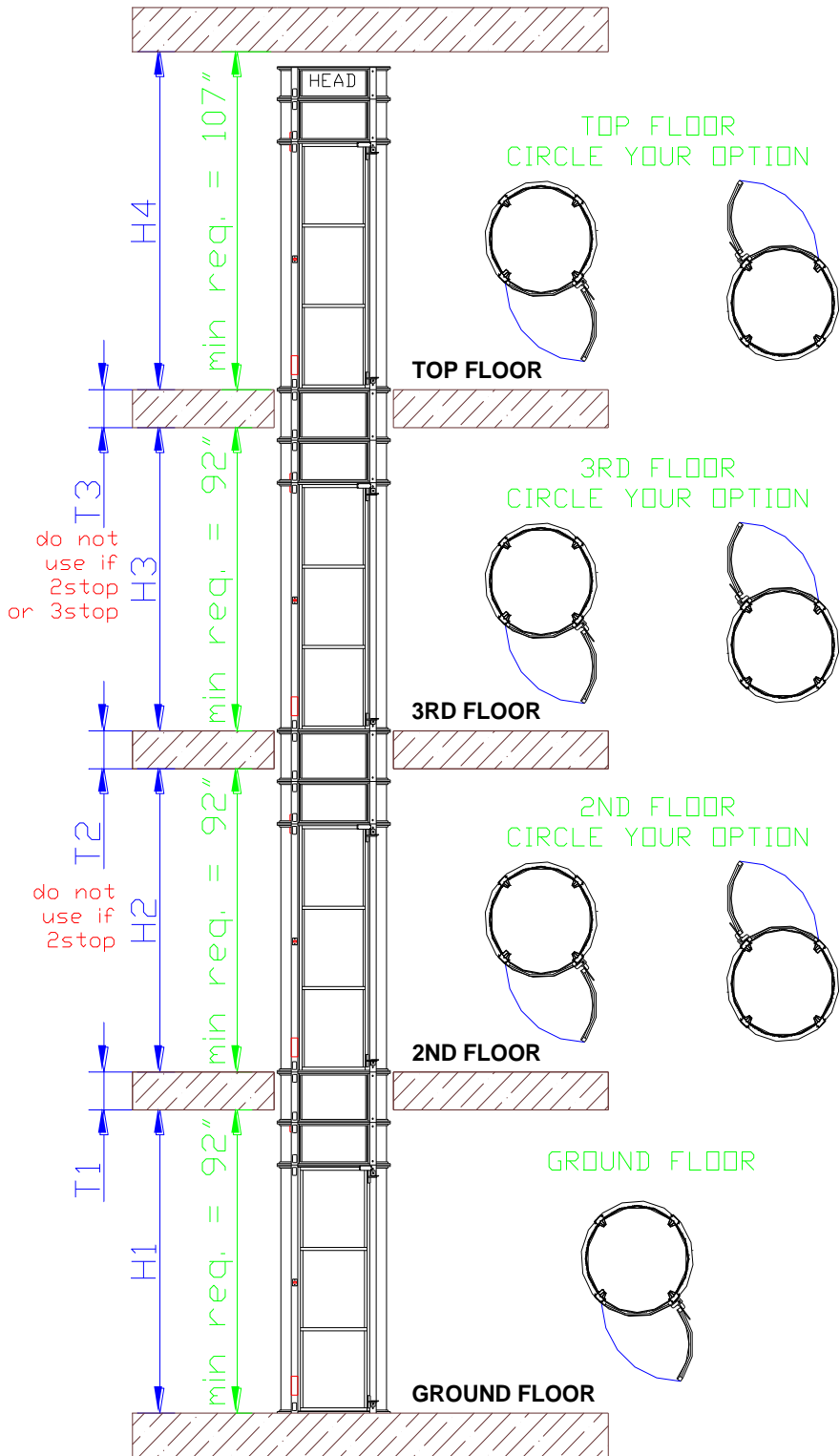

## Elevator Quote Form



End User Name & Address:

---



---

*CIRCLE your OPTION for the following...*

**Model:** PVE30 - PVE37 - PVE52

**No. of Stops:** 2 - 3 - 4

**Color:** Gray (Standard) - Light Gray

White - Black - Taupe

**Travel Heights:**

H1 = \_\_\_\_\_ inches(mm)  
 T1 = \_\_\_\_\_ inches(mm)  
 H2 = \_\_\_\_\_ inches(mm)  
 T2 = \_\_\_\_\_ inches(mm)  
 H3 = \_\_\_\_\_ inches(mm)  
 T3 = \_\_\_\_\_ inches(mm)  
 H4 = \_\_\_\_\_ inches(mm)

**Floor Mount:** (indicate which floor)

T1 = Through Floor or Balcony  
 T2 = Through Floor or Balcony  
 T3 = Through Floor or Balcony

**Split Unit (remote):** Yes - No

If yes, split distance \_\_\_\_\_ ft

**Other Options:**

Cabin Telephone

Cabin Key Lock

Foldable Cabin Seat (PVE37 Only)

Earthquake Brackets



PNEUMATIC  
VACUUM ELEVATORS LLC

## Elevator Quote Form

### Additional Comments