

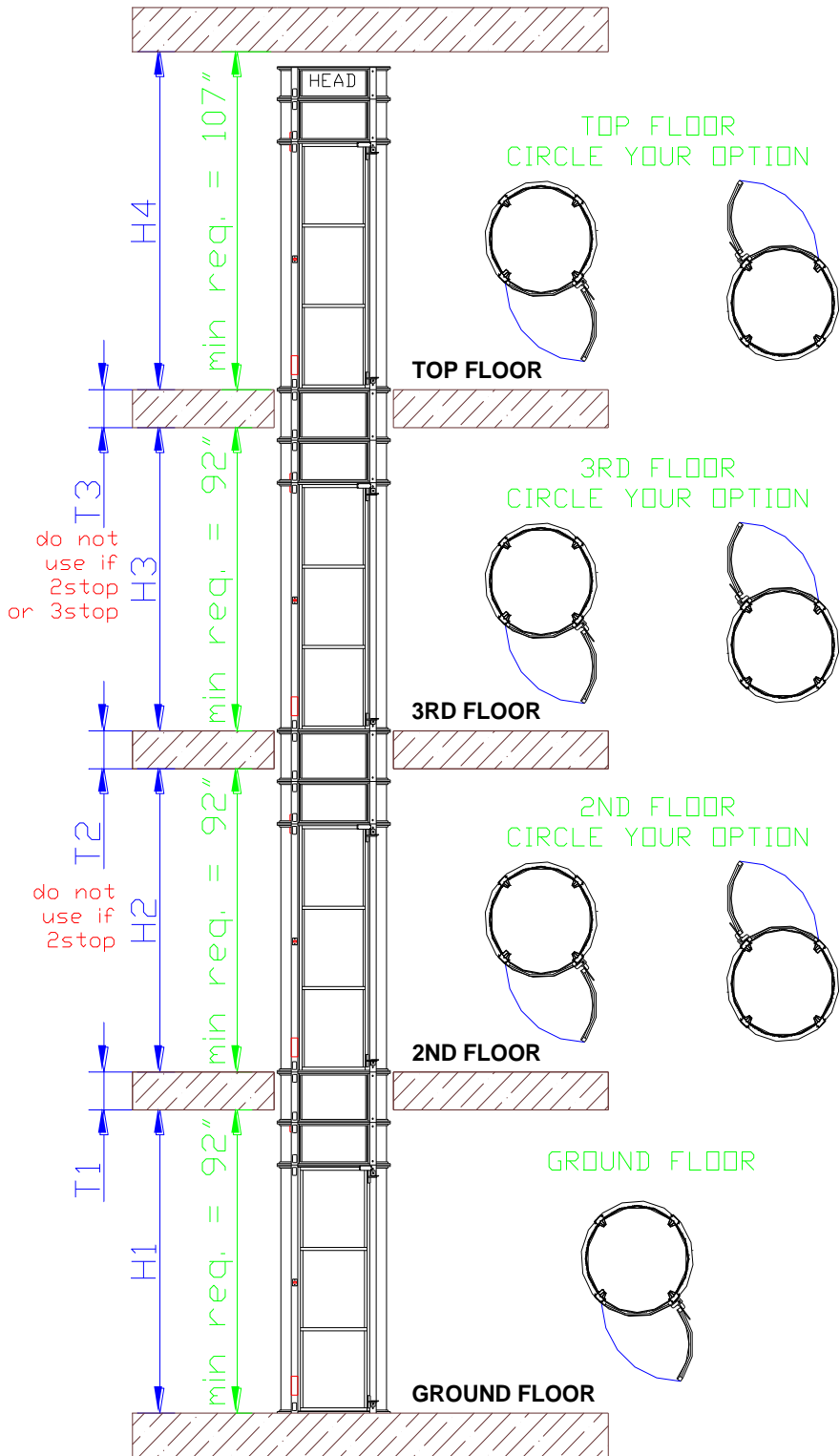

Elevator Order Form



Distributor: _____

End User Name & Address:

CIRCLE your OPTION for the following...

Model: PVE30 - PVE37 - PVE52

No. of Stops: 2 - 3 - 4

Color: Gray (Standard) - Light Gray

White - Black - Taupe

Travel Heights:

- H1 = _____ inches(mm)
- T1 = _____ inches(mm)
- H2 = _____ inches(mm)
- T2 = _____ inches(mm)
- H3 = _____ inches(mm)
- T3 = _____ inches(mm)
- H4 = _____ inches(mm)

Floor Mount: (indicate which floor)

- T1 = Through Floor or Balcony
- T2 = Through Floor or Balcony
- T3 = Through Floor or Balcony

Split Unit (remote): Yes - No

If yes, split distance _____ ft

Other Options:

- Cabin Telephone
- Cabin Key Lock
- Foldable Cabin Seat (PVE37 Only)
- Earthquake Brackets



PNEUMATIC
VACUUM ELEVATORS LLC

Elevator Order Form

Additional Comments